

# PRODUCT OVERVIEW

# DVM - 50X I



## Advanced System Automation

One-touch antenna location and synchronization  
Dual axis motors realign for link acquisition

## System Agnostic

Enclosed and open-air options  
Fully customizable setup allows for near universal list of antenna/radio configurations

## Seamless Installation

Two cables provide both motor control, and data connectivity

## Rapid WWAN Provisioning

BATS uses an industry-first wireless search algorithm that scans the horizon for a compatible signal. Once targeting has occurred, the system scans the wireless lobes to locate the center point, providing quick network links at the highest throughput possible.

## Dynamic System Tracking & Stabilization

With GPS Lobe Optimization, the system routinely checks connection health to detect and immediately counteract any drops or weaknesses in the wireless signal caused by interference, environmental changes, or sudden platform movement. As platform movement occurs, as seen during a mobile deployment, the system will recalibrate and adjust its position in real-time to compensate for directional changes of the base platform in both axis, azimuth and elevation.

## Integrated Control Unit

Streamlined Internal Controller  
SNMP Monitoring & Dynamic Service Level Validation  
WWAN link management with available Link Manager  
HTTPS/SSH/Telnet Management



[www.batswireless.com](http://www.batswireless.com)  
8902 Vincennes Circle  
Indianapolis, IN 46268

Toll Free +1-888-955-8228  
Sales +1-317-500-4507  
Support +1-317-500-4506  
Email [info@batswireless.com](mailto:info@batswireless.com)

# PRODUCT SPECIFICATIONS

# DVM - 50X I

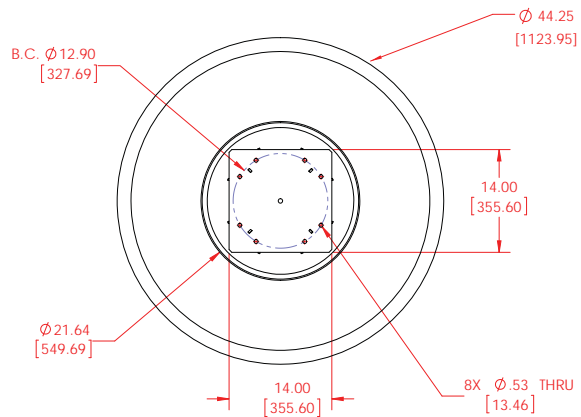
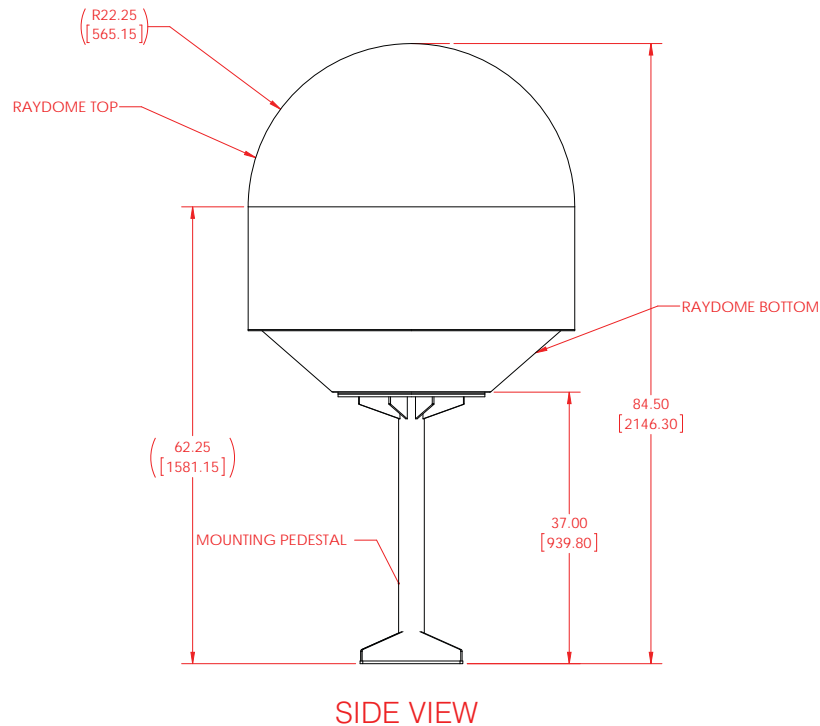

**BOTTOM VIEW WITH PEDESTAL MOUNTING PLATE**

## Specifications

Specifications	
DVM 50x - Domed Vehicle Mount - (50 ft.lb. Load Torque)	
PHYSICAL DIMENSIONS	44.5" x 44.9"
WEIGHT	125 lbs.
ENVIRONMENTAL	Standardized to IP-X6
OPERATING TEMP*	Standard: -30°C - 55°C Optional: -50°C - 55°C
OPERATING POWER	Peak: 173 Watts Standby: 55 Watts
PAN/TILT-AXIS RANGE*	360° Continuous (PAN) ±20° (TILT)
PAN/TILT-AXIS SPEED	0.005° - 50°/sec (PAN) 0.005° - 12°/sec (TILT)
POSITIONER MATERIALS	Marine Grade Configuration, Aluminum Housing, 316 Stainless Steel Hardware, Permanently Sealed Radial Ball Bearings  Finish: Polyester Powder Coat, Chemical Conversion Coating (Alodine) for Corrosion Resistance
CABLING	IP-67 Junction Box (RJ45 & Power Control Cable Access)
MOUNTING*	Pedestal Mount (Required)
AZIMUTH STABILIZATION*	10° / sec (Requires Shipboard BATS GPGGA & HEHDT)
ELEVATION STABILIZATION	0.1° - 6° / sec
ICU 50 - Integrated Control Unit - for DVM 50x	
PHYSICAL DIMENSIONS	3.00" (H) x 8.07" (W) x 7.09" (D)
WEIGHT	3.1 lb.
OPERATING TEMP*	0°C - 55°C (-45°C Option)
OPERATING VOLTAGE	AC: 90 - 265 VAC; 47 - 63 Hz DC: 10 - 36 VDC w/Auto
NETWORK PORTS	(10/100/1000 Mbps)
Components & Accessories	
GPS TARGETING STABILIZER	GPS-Based Signal Targeting & Stabilization
FLEET CONTROLLER	Control Appliance for Multiple Control Units
POSITIONING UNIT CABLING	PU Power Cables, Available up to 330 ft.
MIL-SPEC CABLING	Insulated Cat 5e Cabling, Available up to 330 ft.
MOUNTING HARDWARE	Universal Pole Mount Kits, Radio Mount Kits

\*Additional Components Required